



StoneFire CORE

ONLY Available through Authorized Dealers



**Distinctive Outdoor Living Solutions
Start with StoneFire CORE**



fireplaces

StoneFire CORE fireplaces are high quality and they are the fastest to install compared to other competitor offerings. Our design and construction techniques offer a solid foundation for any Outdoor Living application. **StoneFire CORE** details make a difference:

- Our large fireplace is made up of two pieces that easily fit together.
- Our fireplaces are the only ones in the industry with an integrated raised hearth.
- Our fireplace units have built-in fork lift pockets for easy lifting and placing during installation.
- **StoneFire CORE** fireplaces arrive with a firebox that is lined with firebrick.

large fireplace

MFPL-500



large fireplace 2 ft extended cap

MFPL2X-500



Weight:

Cap: 1,165 lbs.
Base: 3,403 lbs.
Total: 4,568 lbs.

Fireplace alone

Veneer: 109 sq. ft.
Corner: 35 LF

Fireplace with 2 wood boxes

Veneer: 131 sq. ft.
Corner: 29 LF

Firebox opening: 36"W x 29"H x 23"D

large wood box

MWS-200

Dimensions: 40"H x 24"L x 28"D

Weight: 800 lbs

Wood box alone

Veneer: 30 sq. ft.
Corner: 14 LF



Weight:

Cap: 1,450 lbs.
Base: 3,403 lbs.
Total: 4,853 lbs.

Fireplace alone

Veneer: 121 sq. ft.
Corner: 43 LF

Fireplace with 2 wood boxes

Veneer: 143 sq. ft.
Corner: 38 LF

Firebox opening: 36"W x 29"H x 23"D

configurations

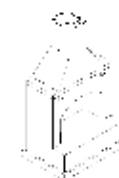
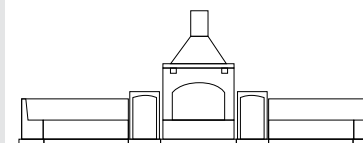

Small or Large
Fireplace - standalone

large fireplace 4 ft extended cap

MFPL4X-500



large fireplace contemporary cap

MFPLSQ-500



small fireplace

MFPL-200



Weight:

Cap: 1,735 lbs.
Base: 3,403 lbs.
Total: 5,138 lbs.

Fireplace alone

Veneer: 133 sq. ft.
Corner: 51 LF

Fireplace with 2 wood boxes

Veneer: 155 sq. ft.
Corner: 46 LF

Firebox opening: 36"W x 29"H x 23"D

Weight:

Cap: 1,540 lbs.
Base: 3,403 lbs.
Total: 4,943 lbs.

Fireplace alone

Veneer: 120 sq. ft.
Corner: 34 LF

Fireplace with 2 wood boxes

Veneer: 142 sq. ft.
Corner: 28 LF

Cap dimensions: 47"L x 49"H (TV space dimensions)

Weight:

Cap: 471 lbs.
Base: 2,188 lbs.
Total: 2,659 lbs.

Fireplace alone

Veneer: 70 sq. ft.
Corner: 18 LF

Fireplace with 2 wood boxes

Veneer: 90 sq. ft.
Corner: 21 LF

Firebox opening: 31"W x 23"H x 16"D



Small or Large Fireplace
With Wood Boxes

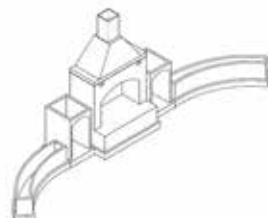

Small or Large Fireplace with
Wood Boxes and Low Walls



Small or Large Fireplace with
Wood Boxes and Seating Walls

small wood box

MWS-100

Dimensions: 40"H x 24"L x 20"D

Weight: 637 lbs.

Wood box alone

Veneer: 24 sq. ft.
Corner: 14 LF



product comparison

StoneFire
CORE

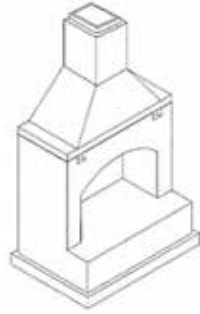

- Unit arrives in 2 pieces.
- Once the unit is on the pad/footing, the veneering process can begin immediately.
- Unit has forklift pockets for easy movement.
- Refractory cement is added to one joint to adhere cap to base.
- Firebox is integrated and pre-installed.
- Unit has a raised hearth.
- This is The Complete Premium Modular Solution!
- Impress your customer by starting a fire the same day the unit is installed!

Competitor

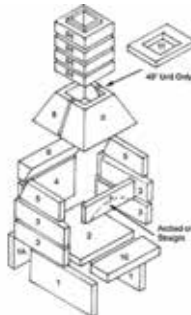

- Kit arrives in multiple parts.
- Unit must be assembled onsite. Installers require 8-12 hours to assemble in order to start veneering.
- Joints must be mortared.
- Firebox is not integrated and must be built.
- Limited modular components available.
- Customers must wait 28 days to allow mortar to cure which means 28 days with **NO** fire!



Scan for our
Comparison Video

reflective protection plates

The **StoneFire CORE** Reflective Protection Plate adds longevity and efficiency to your fireplace.

Our Reflective Protection Plates:

- Are made of 1/2" thick steel for a lifetime of use.
- Reflect more warmth toward you in front of the fireplace instead of losing heat up the flue.
- Create airspace between the coals and the firebox floor to introduce airflow through the grate vents to improve burning efficiency.
- Protect your investment in your fireplace, shielding the firebox from the cumulative effects of extreme heat during repeated fires.

Note: A Reflective Protection Plate must be purchased at original point of purchase and installed with our **StoneFire CORE** fireplaces in order to maintain the firebox warranty.

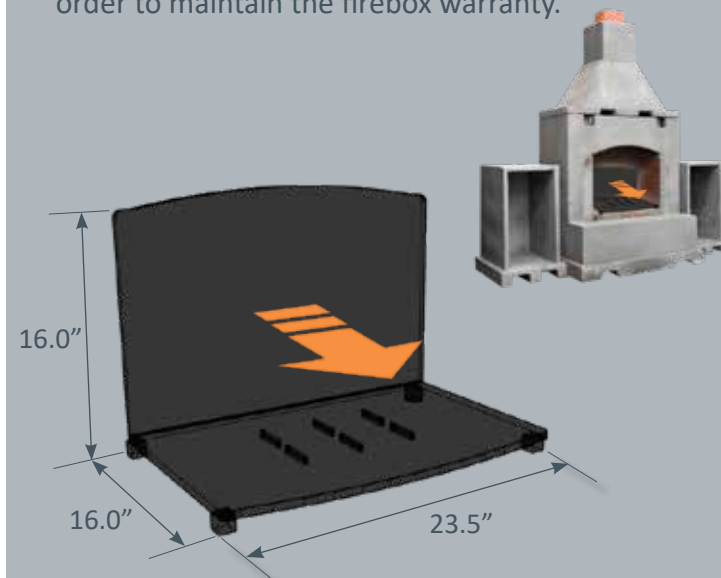

footings

Footings are an important construction detail which provide a solid foundation and contribute to the quality and longevity of Outdoor Living installations.

- **StoneFire CORE** highly recommends a concrete footing when installing our fireplaces and outdoor kitchen islands. Please note that all footings should be 6" below finish patio grade so the base with forklift pockets can be hidden from view.
- CAD drawings for recommended footings are available on the **StoneFire CORE** website. For more informations, please scan the QR code.

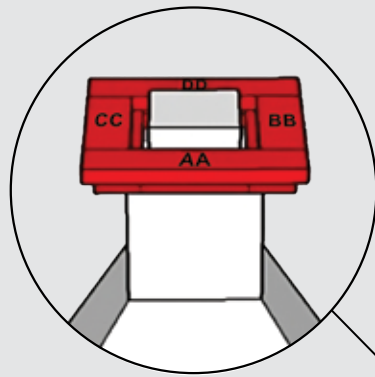

All of our trim kits are made of natural stone to deliver a premium long-lasting, durable finish.

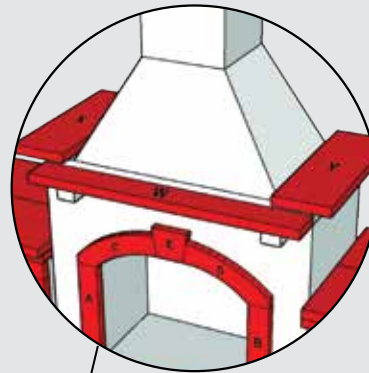

We include key stone, hearth and mantel in our trim kits.

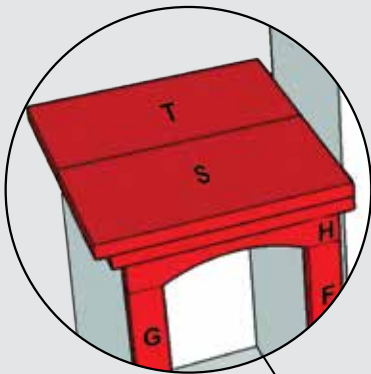

Our wood box is arched like the fireplace to create a custom look and feel.

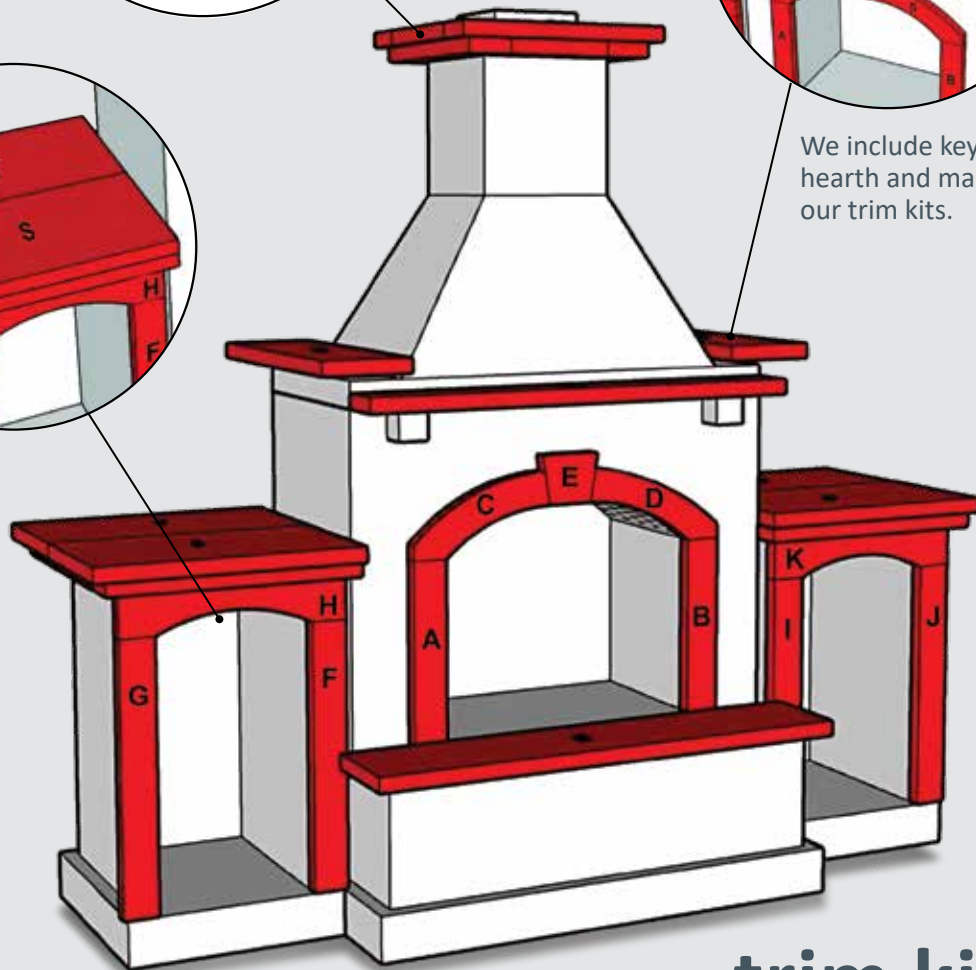

trim kits

Fireplace and wood box trim kits are available to purchase. Trim kit assembly is easy with our labeled diagrams available through your local authorized dealer or on the **StoneFire CORE** website. All pieces are lettered and will correspond to the diagram for accurate placement.

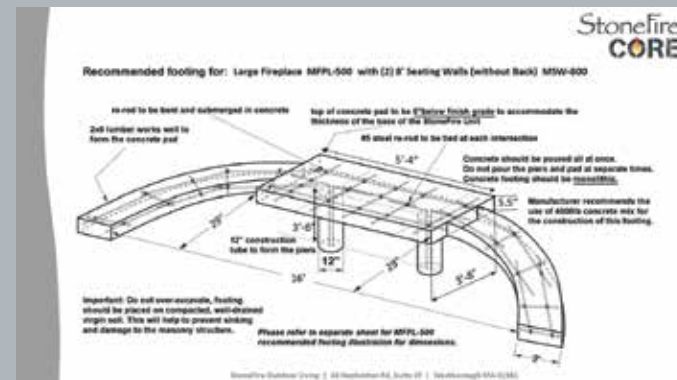

Scan for Assembly Diagrams



Scan for CAD drawings of Footings

fire pits

What could be better than gathering around a warm crackling fire pit and roasting marshmallows with the kids? **StoneFire CORE** fire pits allow you to deliver this dream to your client in an incredibly short turnaround. **StoneFire CORE** details make a difference:

- Our fire pits are one-piece construction.
- Our fire pits have built-in fork lift pockets for easy lifting and placing during installation.



small fire pit MPIT-250

Dimensions:
34" outside dia. x 16"H
(30" inside dia.)

Weight: 622 lbs.

Veneer: 15 sq. ft.
Corner: N/A

medium fire pit MPIT-500

Dimensions:
49" outside dia. x 16"H
(45" inside dia.)

Weight: 1,196 lbs.

Veneer: 20 sq. ft.
Corner: N/A



square fire pit MPITSQ-500

Dimensions:
40 ½"L x 40 ½"W x 18"H
(36 ¾" square, inside)

Weight: 905 lbs.

Veneer: 23 sq. ft.
Corner: 6 LF



bar + grills

There's nothing like sharing a meal with family and friends around an outdoor grilling and eating area. **StoneFire CORE** island cooking solutions provide the perfect foundation to building your outdoor dream kitchen and entertainment area. **StoneFire CORE** details make a difference:

- All sizes can be arranged into L-shaped or U-shaped configurations.
- Our bar + grill islands allow you to easily cut out the proper opening for whatever grill or appliance your client wants to install in their cooking or entertaining area. If it fits in the island footprint, you can install it with ease.
- Our islands are supplied with a backsplash feature which is removable or modifiable as desired.



bar + grill (7 foot): MBAR-700

Dimensions:
40"H x 82"L x 29"D

Weight: 2,190 lbs.

Veneer & Corner:
Depends on appliance
configuration

bar + grill (8 foot): MBAR-800

Dimensions:
40"H x 94"L x 29"D

Weight: 2,483 lbs.

Veneer & Corner:
Depends on appliance
configuration

bar + grill (9 foot): MBAR-900

Dimensions:
40"H x 106"L x 29"D

Weight: 2,700 lbs.

Veneer & Corner:
Depends on appliance
configuration

walls

- **StoneFire CORE** walls can be used as free-standing elements or attached to any of our modular configurations.
- Our wood storage boxes and seating walls are beautiful enhancements to a backyard dream area.
- Our walls can be used as retaining walls or seating areas.
- **StoneFire CORE** walls can be ordered with or without backs.
- Our walls have built-in fork lift pockets for easy lifting and placing during installation.



seating wall with back: MSWB-800

Dimensions:
83"L x 33 ½"H x 22"D

Weight: 2,688 lbs.

Veneer: 55 sq. ft.
Corner: 12 LF

low wall: MSW-800

Dimensions:
77"L x 15 ½"H x 13"D

Weight: 1,003 lbs.

Veneer: 26 sq. ft.
Corner: 6 LF

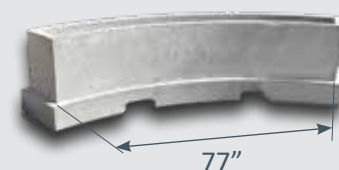

installation is easy



Step 1: Prepare footings.



Step 2: Units are delivered to job site.



Step 3: Place units on footings. Use refractory cement to adhere cap to base.



Step 4: Units fit together like puzzle pieces.



Step 5: Veneer units.



Let the enjoyment of **Outdoor Living** begin!



Scan to See our
Installation Process Video!

StoneFire CORE

Outdoor Living trends are gaining momentum. Today's homeowners are looking to extend their home and entertainment area with an Outdoor Living space that includes a fireplace, fire pit or outdoor kitchen.

Our research indicates that many customers and installers are looking for a more "customizable" approach. Whether you are looking for a turn-key finished solution or a "customizable" approach, it is best to start with a quality "core" foundation to build on.

To address these needs, we are proud to introduce our line of **StoneFire CORE** PCUs (pre-constructed units). **StoneFire CORE** products have earned a reputation for being the highest quality in the industry, providing ease of use and efficiency during installation. By using **StoneFire CORE** products, installers save time and money, and customers enjoy a premium quality Outdoor Living area in the shortest time possible. We are proud to say that the fabrication and construction of our **StoneFire CORE** products have been designed and patented to meet the demands of installers and customers, making them the established industry leader.



Learn more about StoneFire CORE!



PCU

(pre-constructed units)

StoneFire CORE PCUs offer a solid foundation that you can confidently build upon.

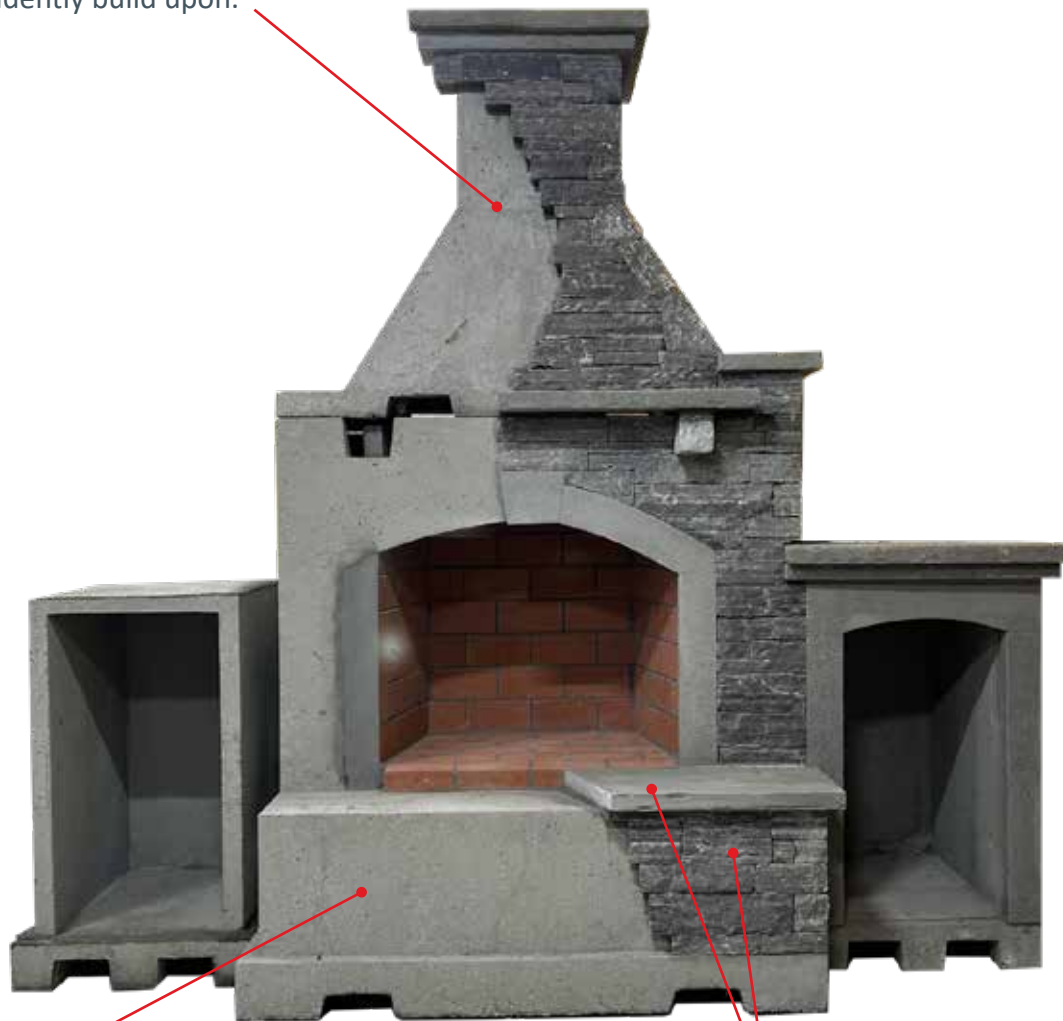

StoneFire CORE PCUs are fabricated with quality materials that are built to last.

Different stones, styles and trims are available. Ask your dealer about finish options today!

Building an Outdoor Living space requires craftsmanship and dedication. Customers should be able to enjoy their investments without worrying about durability or installation problems. **StoneFire CORE** products offer a solid foundation that you can confidently build upon.

Don't have the time or skilled laborer to provide an outdoor feature? **StoneFire CORE** carries a variety of PCU (Pre-Constructed Unit) products to help you deliver outdoor living options to your customers. **StoneFire CORE** PCUs are also offered in a variety of finishes and built to order. Ask your dealer for more details today!

- Start any project with **StoneFire CORE** for a solid foundation.
- **StoneFire CORE** PCUs are created with attention to detail and craftsmanship that has been handed down for generations. Every product delivers premium quality.
- An array of different stones, styles and trims are available. Ask your dealer about finish options today!

Distinctive Outdoor Living Solutions Start with StoneFire CORE





inspiration zone

With so many different configurations and finishes available, **StoneFire CORE** delivers the ultimate package compared to any other brand.

Shown here are a few finish options to help you envision the possibilities. There are a lot more options available to customize a solution to meet your preferred Outdoor Living style.

For more ideas, designs and finishes please visit the **StoneFire CORE** website by scanning the QR code below.



Scan here for
more ideas, designs and finishes...

Advantages:

- Minimal parts translates to the **fastest assembly time in the industry!**
- Start veneering minutes after the unit is placed.
- **Built-in forklift pockets** allow easy movement and placement of units.
- Our Fireplaces include **raised hearths** and **finished fireboxes.**
- Our products are made with **premium, heat-resistant materials** for a **solid foundation.**
- We provide **complete Outdoor Living solutions** including Fireplaces, Fire pits, Wood Boxes, Seating Walls, Columns and Outdoor Kitchens.
- We deliver **quick turnaround**, enabling you to commit to **more projects in a season!**
- **No curing time required!** You can light a fire once the unit is in place and let the enjoyment begin!



Scan to Learn More!

configurations



Small or Large Fireplace
With Wood Boxes

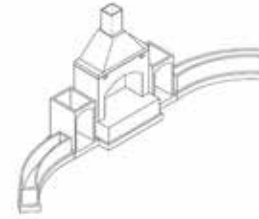

Small or Large Fireplace with
Wood Boxes and Low Walls

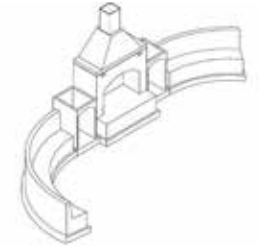

Small or Large Fireplace with
Wood Boxes and Seating Walls

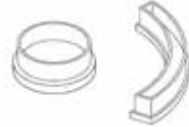

Medium Fire Pit
with Low Wall

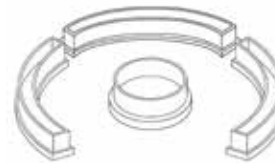

Medium Fire Pit
with Low Walls

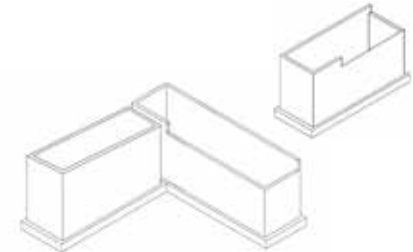

Bar and Grill Islands



Scan to Find
Your Local Authorized Dealer!